

DWS10 Series

Electric Sit-Stand Workstation

LUMI
ergo



Easier & Better Ergonomics

Dual & Triple Monitor Application Included

Sit-stand workstations are one of the fastest growing segments in the ergonomic furniture market. They've become the easiest most versatile way to add sit-stand ability to most any desk.

The DWS10 Series makes the conversion to sit-stand even easier by providing a motorized movement that controls the height with the touch of a button.

The ergonomic design helps the user avoid poor posture by encouraging healthier work habits. Strength in design, quality components, and thorough testing make the DWS10 Series a solid choice in the world of sit-stand workstations.

Great Synthesis of Technical, Ergonomic & Aesthetic Design

DWS10-T01D

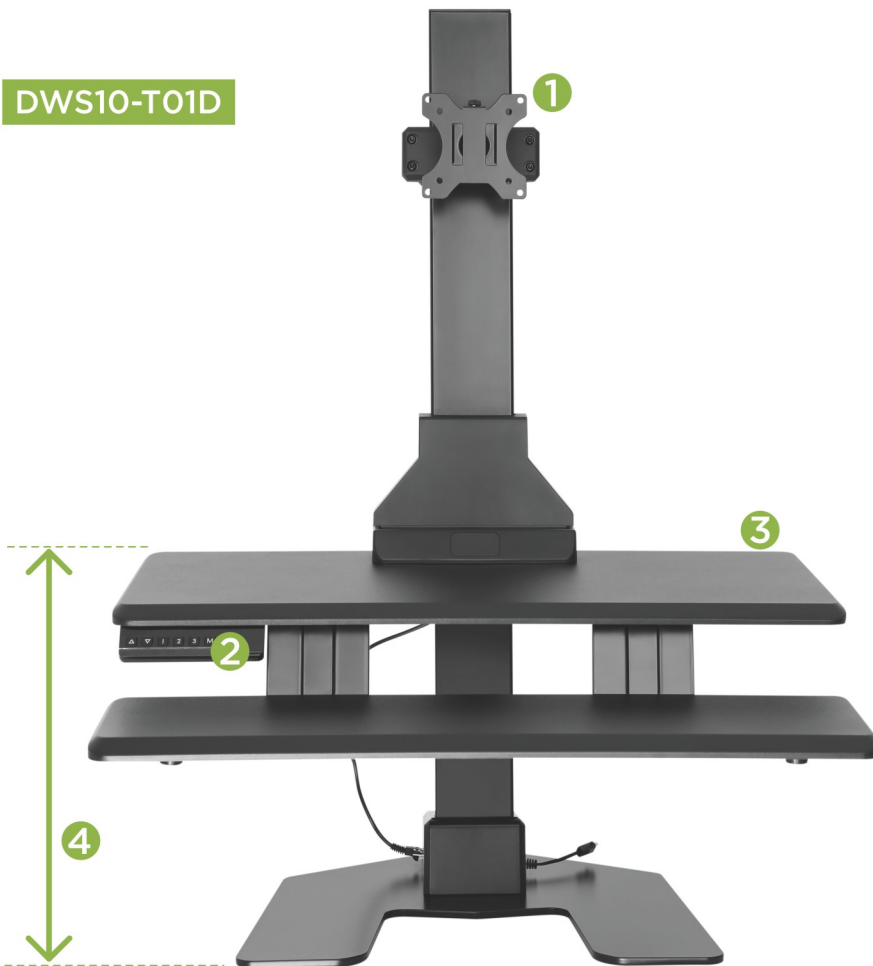

1

- **Tiltable VESA Plate** satisfies better viewing angles.
- **360 Degrees Rotation** for portrait and landscape view.

2

- **Digital Control Panel** activates height adjustment with a fingertip.
- **3 Memory Settings** store desired height adjustment.
- **Timer** helps build a sit-stand habit.

(DWS10-T01D/ DWS10-T02D/ DWS10-T03D only)

3

- **Additional Desktop** for placing tablets, laptops, notebooks and many others.

(DWS10-T01D/ DWS10-T02D/ DWS10-T03D only)

4

- **One Does Fit All-** min100mm-max600mm (3.9"-23.6") large height adjustment range accommodates different sizes.



DWS10-T02D

Dual Monitor Application

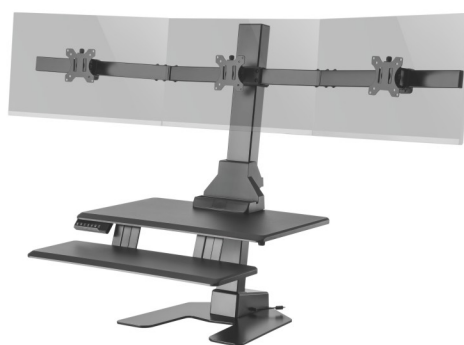

DWS10-T03D

Triple Monitor Application



Integrated Cable Management



Worksurface Organizer

DWS10 Series

Electric Sit-Stand Workstation

Single Monitor

LUMI ergo

DWS10-T01



Color Option: ● ○



Powerful Motor
lifts heavy load on workspace
with a touch of button.

DWS10-T01D



Color Option: ● ○

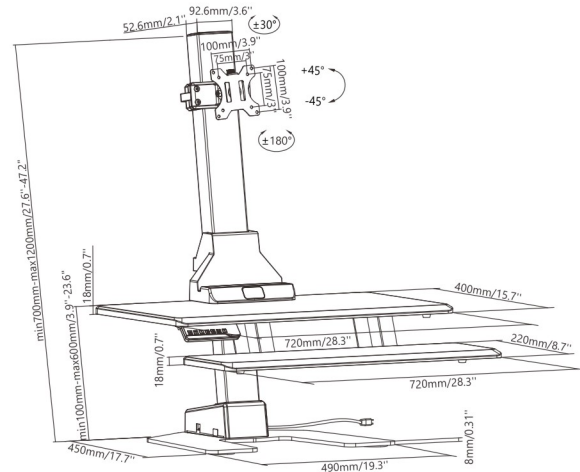
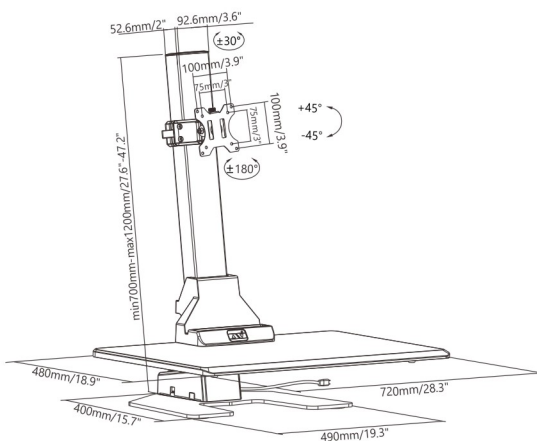

Item No.	DWS10-T01	DWS10-T01D
Model name	Standard Single Monitor Electric Sit-Stand Workstation	Advanced Single Monitor Electric Sit-Stand Workstation
Height range	35-535mm(1.4"-21")	100-600mm(3.9"-23.6")
Worksurface size	720x480mm(28.3"x19")	720x400mm(28.3"x15.7")
Keyboard tray size	/	720x220mm(28.3"x8.7")
Screen size	13"-32"	13"-32"
Tilt	+45° ~ -45°	+45° ~ -45°
Pivot	+30° ~ -30°	+30° ~ -30°
Rotation	+180° ~ -180°	+180° ~ -180°
Monitor weight capacity (per screen)	8kg(17.6lbs)	8kg(17.6lbs)
Keyboard tray weight capacity	/	2kg(4.4lbs)
Material	steel, plastic, wood	steel, plastic, wood
VESA	75x75 100x100	75x75 100x100
Input	100-240V	100-240V
Control mode	motor	motor
Speed	25mm/s	25mm/s

DWS10 Series

Electric Sit-Stand Workstation

Dual Monitor



DWS10-T02



Color Option: ● ○

DWS10-T02D



Color Option: ● ○

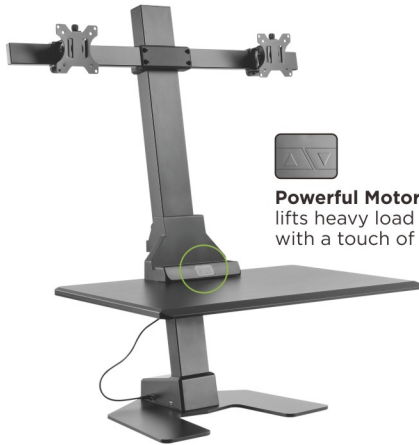

Powerful Motor
lifts heavy load on worksurface
with a touch of button.

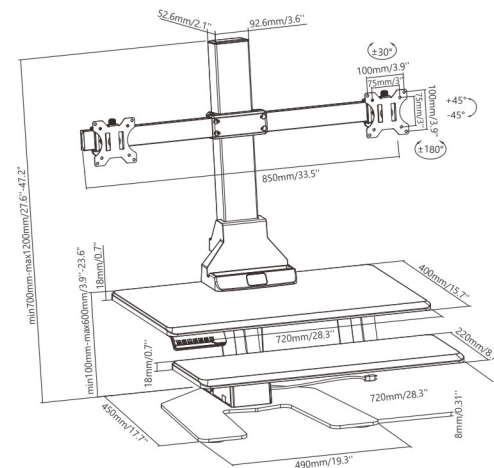
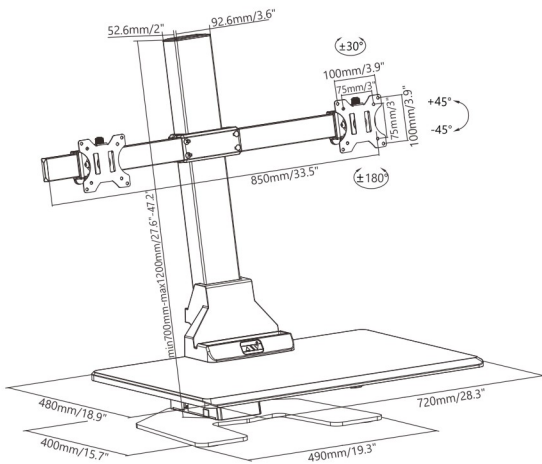

Item No.	DWS10-T02	DWS10-T02D
Model name	Standard Dual Monitor Electric Sit-Stand Workstation	Advanced Dual Monitor Electric Sit-Stand Workstation
Height range	35-535mm(1.4"-21")	100-600mm(3.9"-23.6")
Worksurface size	720x480mm(28.3"x19")	720x400mm(28.3"x15.7")
Keyboard tray size	/	720x220mm(28.3"x8.7")
Screen size	13"-32"	13"-32"
Tilt	+45° ~ -45°	+45° ~ -45°
Pivot	+30° ~ -30°	+30° ~ -30°
Rotation	+180° ~ -180°	+180° ~ -180°
Monitor weight capacity (per screen)	8kg(17.6lbs)	8kg(17.6lbs)
Keyboard tray weight capacity	/	2kg(4.4lbs)
Material	steel, plastic, wood	steel, plastic, wood
VESA	75x75 100x100	75x75 100x100
Input	100-240V	100-240V
Control mode	motor	motor
Speed	25mm/s	25mm/s

DWS10 Series

Electric Sit-Stand Workstation

Triple Monitor



DWS10-T03



Color Option: ● ○

DWS10-T03D



Color Option: ● ○

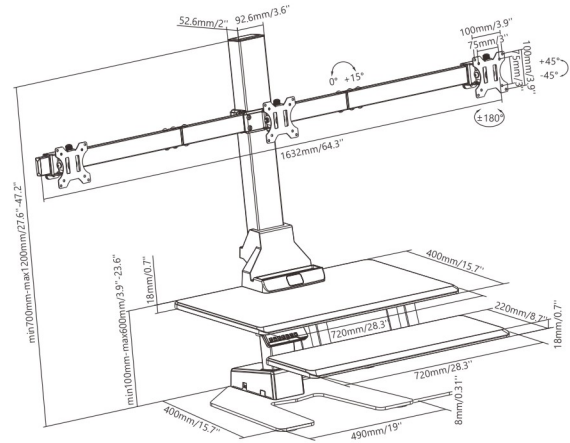
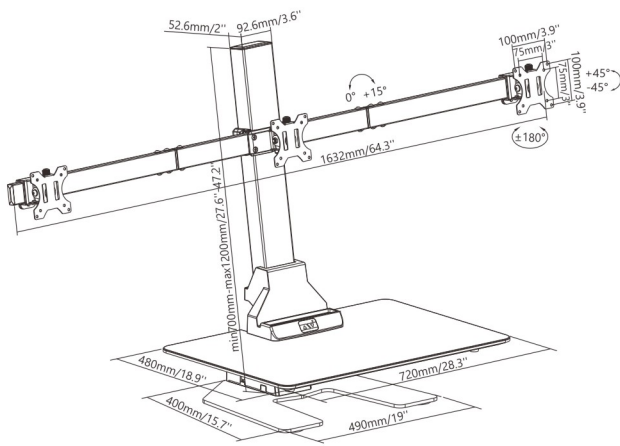
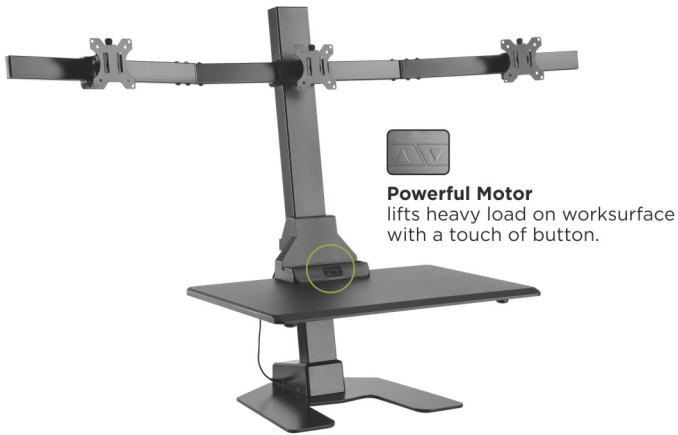

Item No.	DWS10-T03	DWS10-T03D
Model name	Advanced Triple Monitor Electric Sit-Stand Workstation	Advanced Triple Monitor Electric Sit-Stand Workstation
Height range	35-535mm(1.4"-21.1")	100-600mm(3.9"-23.6")
Worksurface size	720x480mm(28.3"x18.9")	720x400mm(28.3"x15.7")
Keyboard tray size	/	720x220mm(28.3"x8.7")
Screen size	17"-32"	17"-32"
Tilt	+45° ~ -45°	+45° ~ -45°
Pivot	+15° - 0°	+15° - 0°
Rotation	+180° ~ -180°	+180° ~ -180°
Monitor weight capacity (per screen)	8kg(17.6lbs)	8kg(17.6lbs)
Keyboard tray weight capacity	2kg(4.4lbs)	2kg(4.4lbs)
Material	steel,MDF & PVC,aluminum,plastic	steel,MDF & PVC,aluminum,plastic
VESA	75x75 100x100	75x75 100x100
Input	100-240V	100-240V
Control mode	motor	motor
Speed	25mm/s	25mm/s